

WEIGHT CLASS  
**2.5 TONNE**  
| TB325R |



# SHORT TAIL SWING EXCAVATOR

**STAGEV  
READY**



**takeuchi**  
From World First to World Leader

# NEW 3-SERIES mini excavator **TB325R**

The TB325R is from the NEW 3-SERIES of Takeuchi excavators, a short tail, trailer towable 2.5 tonne compact excavator.

The TB325R is available as a cab or canopy option and weighs-in under 2.5 tonne for safe legal towing.

With a powerful 16.5kW engine output and breakout force of 19.3kN this compact short-tail mini excavator provides maximum performance and versatility on site.

The New TB325R combines all the proven characteristics of Takeuchi excavators - smooth hydraulics, powerful machine performance and great serviceability.



## SHORT TAIL SWING

The short tail design offers excellent accessibility where space is limited.

The TB325R with just 825mm slew radius and a compact rear side, will work close to walls minimising potential machine damage.

The TB325R has just 7cm overhang at 90° to track.

With a low centre of gravity and optimized counterweight the TB325R offers an extremely stable platform for excavating at 90° to track.

## OPERATOR COMFORT

The large and roomy cab and canopy feature ergonomic design with easy-to-use pilot controls and a large colour VDU. Auxiliary hydraulic flows and presets can be adjusted from the comfort of the operator's seat.

The large fully adjustable suspension seat and armrest provide comfort for all day operating.

Excellent all-round visibility - the cab features gas assist front window and removable/stowable lower glass.







## ENHANCED FEATURES

Stage V ready (<19kW engine) the TB325R is emission compliant with low noise levels.

Automatic Step-down Travel Motors – provide torque on demand when pushing, climbing, or turning in high speed mode.

Choice of Auxiliary Service Ports – 1st, 3rd pre-piped with hitch pipework as standard. Optional 2nd auxiliary.

LED workzone lighting and maximum all round visibility with unobstructed blindside window.

## OPERATOR STATION

- Cab – skylight, lift-assist front window and stow-away lower glass
- Blindside sliding glass window 60/40
- Cab - MW/FM radio / MP3 / USB/ Bluetooth with stereo speakers
- Cab multi-vent heater / de-mister
- Footrests and offset foot pedal

## ELECTRICAL

- Sealed rocker switches
- Internal / power sockets - 12V / USB
- Switched roof beacon socket - 12V
- Travel alarm / horn
- Cab - LED (boom/ roof/ internal)
- Canopy – LED (boom / roof)
- TSS (Takeuchi Security System Immobilizer)

## ENGINE

- Stage V Ready < 19kW - low emission
- Automatic fuel bleed system
- Automatic engine idle feature
- Automatic cold start device
- Dual fuel filtration with water trap
- Dual element air filter
- Service interval - 250 hours



## HYDRAULICS

- Cushioned boom and arm cylinders
- Main boom and blade cylinder guard
- Auxiliary hydraulics with independent isolation valves
- Primary auxiliary circuit with switched auto tank
- Proportional auxiliary controls with detent
- Switched 1/2-way aux flow

## UNDERCARRIAGE & FRAME

- Load sensing two speed travel with automatic shift
- Triple flanged track rollers
- Sealed bearing top rollers
- Ground level hose spiral protection
- Easy tension grease filled track adjusters



## TRAILER TOWABLE

Weighing in at just 2440kg cab and 2310kg canopy inclusive of both a hitch and bucket - the TB325R provides the most powerful yet portable mini digger.

With 4 dedicated tie-down anchor points the safest possible transporting is assured.

When combined with a trailer, spare buckets, tools and materials, safe compliant road towing within the 3.5-tonne regulations is guaranteed.





**SERVICEABILITY**

Rear service door – allows access to the dipstick, engine oil fill, engine oil filter, air cleaner, battery, battery isolator switch and hydraulic pump pressure detection points. Clustered service points make for quick and easy regular service routines to maintain machine performance.

Right side lockable service panel provides excellent access to the hydraulic tank, hydraulic filter, fuel tank, coolant expansion tank and grease gun storage point.

Lower service panel provides storage for tool bag as well as convenient access to the water separator.

The undercarriage features maintenance-free sealed bearings and triple flanged track rollers to help maintain track performance.



**ROBUST FOR SITE**

The TB325R is built with an all steel construction. The dozer and main boom cylinder guards offer maximum all round protection. The ground level hydraulic pipework is spiral steel wrapped for maximum on site durability.



**PROTECT YOUR INVESTMENT**

The TB325R comes with the TSS Takeuchi Security System as standard. Optional for TFM Takeuchi Fleet Management



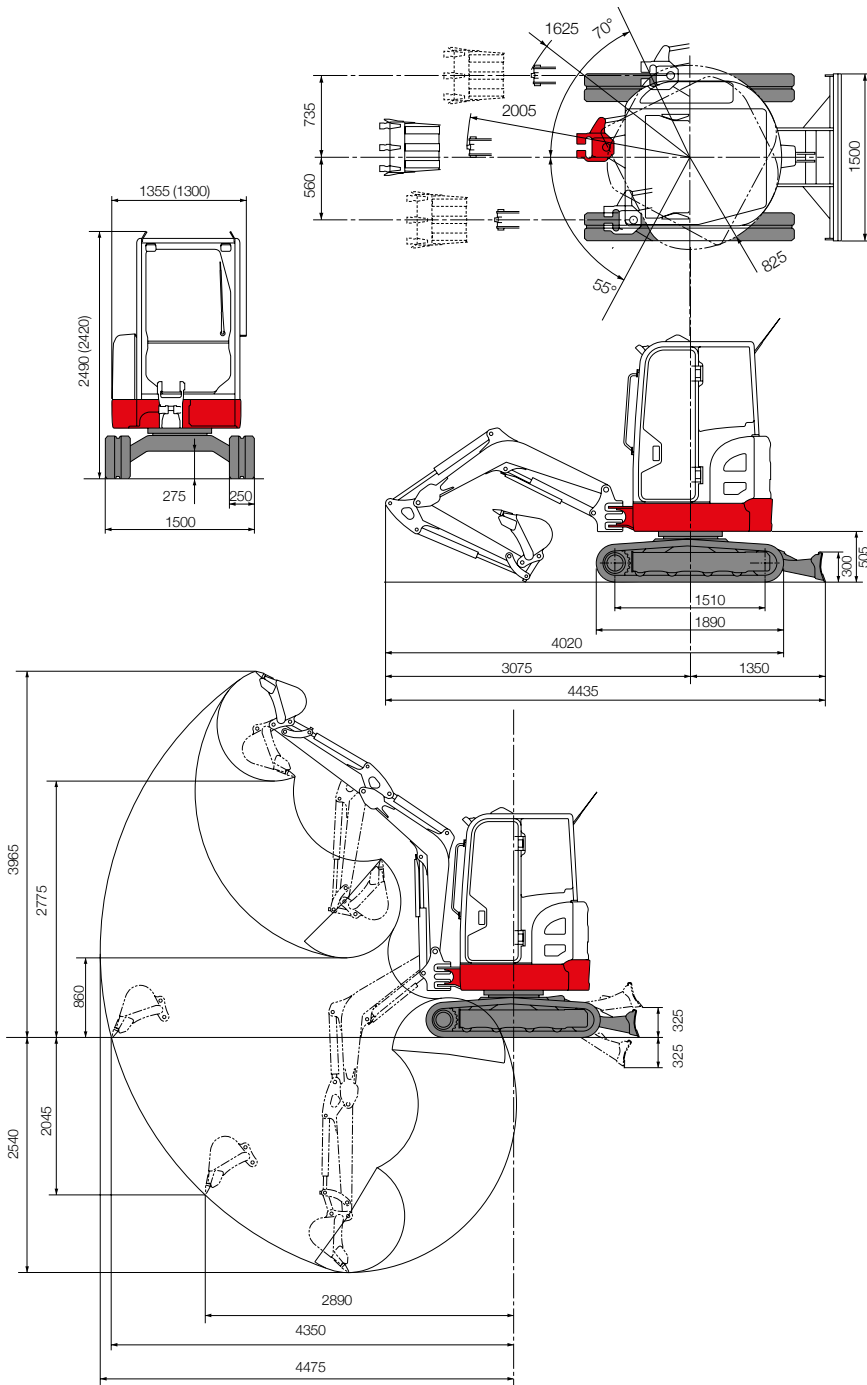

## TB325R

Standard UK Specification - Rubber Track, Long Arm

Engine	
Make	Yanmar
Model	3TNV82A
Rated Output (kW)/rpm	16.5 / 2200
Maximum Torque (Nm)	85.1
Cylinders	3
Displacement (cc)	1330
Electrical System	12V / 58A
Dimensions & Weight	
Operating Weight inclusive of bucket, hitch and fuel (kg) Cab/Canopy	2440 / 2310
Overall Length (mm)	4020
Overall Length dozer at rear (mm)	4435
Width cab/canopy (mm)	1500
Height cab/canopy (mm)	2490 / 2420
Ground Clearance (mm)	275
Min. Front Swing Radius (mm)	1625
Tail Swing Radius (mm)	825
Dozer Blade (W x H) (mm)	1500 x 300
Operating Information	
Max Digging Depth (mm)	2540
Max Dump Height (mm)	2775
Max Reach at Ground Level (mm)	4350
Max Vertical Digging Depth (mm)	2045
Max Bucket Digging Force (kN)	19.3
Max Arm Digging Force (kN)	11.3
Hydraulic System	
Main System Pressure (bar)	210
Pump Type	Variable x 2 + Gear x 2
1st Auxiliary Maximum Flow (l/min) / Pressure (bar)	40 / 210
*2nd Auxiliary Maximum Flow (l/min) / Pressure (bar)	14.7 / 196
Swing System	
Boom Swing Angle (R/L)	55 / 70
Slew Speed (rpm)	8.9
Slew Motor	Axial Piston
Slew Brake	Wet Friction Plate
Undercarriage	
Traction Motor	Axial Piston
Traction Drive	Planetary
Traction Brake	Disc
Track Width (mm)	250
Ground Contact Length (mm)	1510
Ground Pressure (kpa)	29.1 / 27.6
Travel Speed (km/h)	2.5 / 4.3
Maximum Gradeability	25
Capacities	
Hydraulic System (l)	48
Fuel Tank (l)	31.2
Engine Lubrication (l)	3.6
Cooling System (l)	4.7

All dimensions unless otherwise stated are in millimeters.

**OPTIONS:** Hydraulic breaker, hitches, buckets.

TFM Fleet Management \*Factory fitted option - 2nd Auxiliary and change over valve.

**2 YEAR  
2,000 HOUR  
WARRANTY\***

Takeuchi machines come with a 2 year/2000 hours warranty as standard. Warranty exceptions to 1 year: fuel injection systems, electrical components, paint work and \*emission control items. (\*applicable models).

Before fitment of a hydraulic attachment, machine auxiliary pressure and flow should be accurately measured.

In accordance with our established policy of constant improvement, we reserve the right to amend these specifications at any time without notice. Photographs shown may feature non-standard equipment.

06/2021

**For more information locally contact:**

Takeuchi Mfg (UK) Ltd, Unit E2B Kingsway Business Park,  
John Boyd Dunlop Drive, Rochdale, Lancashire OL16 4NG  
Tel: 01706 657 722 Email: info@takeuchi-mfg.co.uk  
www.takeuchi-mfg.co.uk



**TAKEUCHI**  
From World First to World Leader